MP 4.1 – SUSTAINABLE BUILDINGS

Table of Contents

Purpose.....	2
Commencement.....	2
Application.....	2
Referral Agency.....	3
Compliance with the QDC.....	3
Associated Requirements.....	3
Referenced <i>Standards</i>	4
Definitions.....	4
Energy Efficiency – <i>class 1</i> buildings.....	9
Energy Efficiency – <i>class 2</i> buildings.....	10
Energy Efficient <i>Domestic Services</i>	11
Water Conservation.....	12
Electricity Sub-metering.....	12
<i>End of Trip Facilities</i>	13
Schedule 1.....	15
Schedule 2.....	16
Schedule 3.....	17
Schedule 4.....	18

Purpose

To ensure:

- (a) *class 1* and *class 2* buildings are energy and water efficient;
- (b) the *electricity* supplied to each *meterable premises* is able to be measured appropriately; and
- (c) *end of trip facilities* are provided in *major developments* located in *designated local government areas*.

Commencement

This version of Mandatory Part (MP) 4.1:

- (a) commences on 6 August 2012; and
- (b) replaces the version of MP 4.1 published on 27 June 2011.

Application

- (1) This part applies to the lawful carrying out of building work as indicated by ticks (✓) in the relevant columns in Table 1 below, subject to (2).
- (2) This part and the *relevant BCA provisions* do not apply to the lawful carrying out of building work¹ to a class 1 building where:
 - (a) any of the following applies:
 - (i) a building certifier has, by written notice given to the owner, certified that the building has been affected by a flood or storm surge; or
 - (ii) the building is located in a *natural hazard management area (flood)*; or
 - (iii) a local government has, by written notice given to the owner or notice published on the local government’s website, declared that the building is likely to be affected by a future flood or storm surge; and
 - (b) a building certifier certifies the work is, or directly relates to, raising the building.

Note: Reference should also be made to sections 36, 37, 61 and 81 of the *Building Act 1975*, which may affect the application of MP 4.1.

Table 1 – Application of MP 4.1

Applications	Performance Requirements												
	1	2	3	4	5	7	8	9	10	11	12	13	
Construction of <i>new class 1</i> buildings.	✓		✓		✓	✓	✓	✓					
<i>Renovation</i> of a <i>class 1</i> building.	✓		✓		✓								
<i>Other renovation</i> of a <i>class 1</i> building.	✓		✓		✓	✓	✓	✓*					
Construction of <i>new class 2</i> buildings.		✓		✓		✓	✓	✓	✓	✓	✓		

¹ Any plumbing work included in the work in (2) is notifiable minor work; see schedule 2 part 1 of the *Standard Plumbing and Drainage Regulation 2003*.

MP 4.1 – SUSTAINABLE BUILDINGS

Renovation of a sole-occupancy unit in a class 2 building.		✓		✓								
Other renovation of a sole-occupancy unit in a class 2 building.		✓		✓		✓	✓	✓*				
Installation of an air-conditioner in a class 1–10 building.												
Construction of a new class 5 building.									✓	✓	✓	
Construction of a new major development or a major addition to a major development located in a designated local government area.												✓

* **Note:** This applies to only the new work included in the *plumbing approval*. This is an applied provision under the *Standard Plumbing and Drainage Regulation 2003*

Referral Agency

Local government is the referral (concurrence) agency as per item 28 in Schedule 7 Table 1 of the *Sustainable Planning Regulation 2009* for building development applications to which *Performance Criteria P13* applies.

Compliance with the QDC

Under section 14 of the *Building Act 1975*, compliance with this part can be achieved only by:

- (a) complying with the relevant *acceptable solution* for the *performance criterion*; or
- (b) formulating an *alternative solution* that complies with the *performance criteria* or is shown to be at least equal to the relevant criteria; or
- (c) a combination of (a) and (b).

Associated Requirements

- *Body Corporate and Community Management Act 1997*
- *Building Act 1975*
- Building Code of Australia (BCA)
- *Building Regulation 2006*
- *Electricity Act 1994*
- Electricity Regulation 2006
- *Electrical Safety Act 2002*
- Electrical Safety Regulation 2002
- *Plumbing and Drainage Act 2002*
- Plumbing Code of Australia
- Queensland Plumbing and Wastewater Code
- Standard Plumbing and Drainage Regulation 2003
- *Sustainable Planning Act 2009*
- Sustainable Planning Regulation 2009
- *Water Efficiency Labelling and Standards Act 2005*
- *Water Supply (Safety and Reliability) Act 2008*

Referenced Standards

AS 62053.21: 2005	Electricity metering equipment (AC)–Particular requirements Part 21: Static meters for active energy (classes 1 and 2)
AS 1284.1:2004	Electricity metering – General purpose induction watt-hour meters
AS 2890.3: 1993	Parking facilities Part 3: Bicycle parking facilities (including modifications as specified in Schedule 2)

Definitions

Note: Italicised words in the text of the part are as defined below.

Acceptable solution means a relevant building solution which is deemed to satisfy the relevant *performance criterion* for the purposes of section 14 (4) (a) (ii) of the *Building Act 1975*.

Alteration has the meaning given in the *Building Act 1975*.

BCA has the meaning given in the *Building Act 1975* unless a particular edition of the Building Code of Australia published by the Australian Building Codes Board, including any amendments published by the board for that year, is specified (for example *BCA 2009*).

Bicycle means a two-wheeled vehicle designed to be propelled by human power and with overall dimensions within those specified by AS 2890.3:1993.

Bicycle parking and storage facility means an area or structure used for parking, storage or securing of *bicycles*, which provides a level of security for the *bicycle* in accordance with the security classifications provided in AS 2890.3:1993 (including modifications as specified in Schedule 2).

Change room means a room where an *occupant* is able to change clothes in privacy, either individually or on a gender basis and that contains washbasins, mirrors, *showers* and *sanitary compartments*.

Classes 1 to 10 has the meaning given in the *BCA*.

Climate zone has the meaning given in the *BCA*.

Commercial office building means a *class 5* building as classified under the *BCA*.

Common area means an area of *common property*.

Common property means the lot allocated to the body corporate for the *community titles scheme*.

Community titles scheme has the meaning given in section 10 of the *Body Corporate and Community Management Act 1997*.

Customer has the meaning given in the *Electricity Act 1994*.

Designated local government area means—

- a) the area of the local governments identified in Schedule 1; or
- b) for local governments not identified in Schedule 1:
 - (i) the area identified in a local government planning scheme as a *designated local government area* for the purpose of this code; or
 - (ii) the area identified by a local government resolution as a *designated local government area* for the purpose of this code where notice of the resolution is published:
 - (A) in a newspaper that is circulating generally in the local government area; and
 - (B) on the local government's website.

Domestic services has the meaning given in the *BCA*.

Electricity includes electric current, electrical energy and the like, and any related physical qualities.

Electricity meter means a device that measures and records the production or consumption of *electricity*.

Electricity sub-meter means a device that measures and records the production or consumption of *electricity* that either:

- a) is a minimum accuracy *class 1* under AS62053.21:2005; or
- b) complies with AS1284.1:2004.

Employee has the meaning given in the *Industrial Relations Act 1999*.

End of trip facility means a facility within a building or on-site that is required to be constructed in compliance with P13(1) of this part.

Energy efficient lighting is lighting with a minimum output of 27 lumens per Watt and excludes a heat lamp used in a bathroom for the purposes of radiating heat.

Entrance means a main path into a building that is not for emergency use.

Floor area has the same meaning as given in the *BCA*.

Full time equivalents for *workforce numbers* includes full time aggregates of part-time and casual *employee* hours.

Hospital means a *class 9a* building as classified under the *BCA*.

Locker means a compartment for storage that can be securely locked.

Major addition means any addition to an existing *major development* that results in additional *floor area* of at least 1000m².

Major development means a:

- a) *commercial office building* with a *floor area* greater than 2000m²; or
- b) *shopping centre* with a *floor area* greater than 2000m²; or

- c) *tertiary educational facility* with a *floor area* greater than 2000m²; or
- d) *hospital* with a *floor area* greater than 2000m²; or
- e) development specified in a local government planning scheme as a major development for the purposes of QDC MP 4.1

Note: Local governments may specify additional development to be *major development*.

Meter label means a label of white heat-resistant material with black lettering fixed by means of screws, rivets or glue that clearly identifies each *meterable premise*.

Meterable premises means:

- a) the *sole occupancy unit* of a *class 2* or *class 5* building that is or will be connected to a supply of *electricity*, except where a *sole occupancy unit* of a *class 2* or *class 5* building has or will have an *electricity meter* as a *customer* of a *retail entity* or *special approval holder*; or
- b) each *storey* of a *class 5* building that is or will be connected to a supply of *electricity* where more than one *sole occupancy unit* for that *storey* has not been identified at the time of the building's development approval for building work, except where a *storey* of a *class 5* building has or will have an *electricity meter* as a *customer* of a *retail entity* or *special approval holder*.

Natural hazard management area (flood) means an area designated as a natural hazard management area (flood) by a local government under the *Building Regulation 2006*, section 13.

New means *new building work* and does not include *renovations* to existing buildings.

Occupants means the number of persons accommodated in the building, as calculated in accordance with *BCA Volume One Table D1.13 (Area per person)* and for the purposes of calculating *occupants* in Schedule 3, '*hospital*' means 'patient care areas', '*shopping centre*' means 'shop', '*tertiary education facility*' means 'school' and '*commercial office building*' means 'office'.

Other renovation means any *alteration* or addition to an existing *class 1* building or the *sole occupancy unit* of a *class 2* building which requires a building development approval and a *plumbing approval*.

Outdoor living area means a space that:

- a) is directly accessible from, and attached to, a living area of the building such as a lounge, kitchen, dining and family rooms; and
- b) has a minimum *floor area* of 12.0m² and a minimum dimension in all directions of 2.5 metres; and
- c) is fully covered by an impervious roof; and
- d) has:
 - (i) for *class 1* buildings - two or more sides open or capable of being readily opened, not including the connection between the internal living area and the *outdoor living area*; or
 - (ii) for *class 2* buildings - at least one side open or capable of being readily opened, not including the connection between the internal living area and the *outdoor living area*.

Performance requirement has the meaning given in the *Building Act 1975*.

Plumbing approval means the compliance assessment processes, compliance permit or compliance certificate, under sections 78 and 79 of the *Plumbing and Drainage Act 2002* for ensuring that plumbing, drainage and on-site sewerage systems complies with the *Plumbing and Drainage Act 2002* and *Standard Plumbing and Drainage Regulation 2003*.

Relevant BCA provisions means section 3.12 in Volume Two of the *BCA*.

Renovation means any *alteration* or addition to an existing *class 1* building or the *sole occupancy unit* of a *class 2* building requiring building development approval.

Retail entity has the meaning given in the *Electricity Act 1994*.

Sanitary compartment has the meaning given in the *BCA*.

Shopping centre means premises comprising two or more individual tenancies that is comprised primarily of shops and which function as an integrated complex.

Shower means a separate and lockable compartment equipped with a showerhead.

Special approval holder has the meaning given in the *Electricity Act 1994*.

Software rating means an energy rating under the Nationwide House Energy Rating Scheme using a calculation method that complies with the Australian Building Codes Board Protocol for Houses Energy Rating Software.

Sole occupancy unit has the meaning given in the *BCA*.

Standard means the edition of Australian Standard AS 62053.21, AS 1284.1 and AS 2890.3 referenced by this part.

Storey has the meaning given in the *BCA*.

Tertiary educational facility means a *class 9b* building that is in a university, college or similar establishment and does not include a primary or secondary school.

Total R-Value has the meaning given in the *BCA*.

Unisex design is suitable for any gender.

Water service is defined by the *Water Supply (Safety and Reliability) Act 2008*.

Water service provider for premises, means the person registered under the *Water Supply (Safety and Reliability) Act 2008*, chapter 2, part 3, as the *water service provider* for retail *water services* for the premises.

Workforce numbers means the number of day time *employees* that are *full time equivalents*.

PERFORMANCE REQUIREMENTS**Energy Efficiency – class 1 buildings**

P1 The thermal performance of a *class 1* building and an enclosed *class 10a* building attached to a *class 1* building must comply with *performance requirement P2.6.1* of the *BCA 2010* (Volume 2).

ACCEPTABLE SOLUTIONS

- A1** (1) A *class 1* building, including an enclosed *class 10a* building attached to a *class 1* building, complies with:
- (a) parts 3.12.1, 3.12.2, 3.12.3, and 3.12.4 of the *BCA 2010* (Volume 2) except, for buildings in *climate zones 1* and *2*, disregard 3.12.1.5(a)(i) and (iii); or
 - (b) verification using a reference building in accordance with V2.6.2.2 of the *BCA 2010* (Volume 2); or
 - (c) a *software rating* of not less than 6 stars; or
 - (d) in *climate zones 1, 2* and *5*, a combination of a *software rating* of not less than 4.5 stars and a nominal credit obtained under (2) to reach a total of 6 stars; or
 - (e) in *climate zone 3*, a combination of a *software rating* of not less than 5 stars and a nominal credit obtained under (2) to reach a total of 6 stars; or
 - (f) part 3.12 of the *BCA 2009* (Volume 2), where a nominal credit of not less than 1 star is obtained under (2).
- (2) For the purposes of (1)(d)-(f) the following nominal credits apply:
- (a) 0.5 star where a building includes an *outdoor living area*, the roof covering of which achieves a *Total R-Value* of at least 1.5 for downward heat flow;
 - (b) 1 star where a building includes an *outdoor living area* the roof covering of which achieves a *Total R-Value* of at least 1.5 for downward heat flow and the

PERFORMANCE REQUIREMENTS**ACCEPTABLE SOLUTIONS****Energy Efficiency – class 2 buildings**

- | | | | |
|-----------|--|-----------|---|
| P2 | The thermal performance of <i>sole occupancy units</i> in <i>class 2</i> buildings complies with <i>performance requirement JP1</i> of the <i>BCA 2009</i> (Volume 1). | A2 | <p>(1) The thermal performance of <i>sole occupancy units</i> in <i>class 2</i> buildings complies with <i>JV1</i> of the <i>BCA 2009</i> (Volume 1) except that:</p> <p>(a) for <i>JV1(a)(i)</i> each <i>sole occupancy unit</i> has a <i>software rating</i> of not less than 4 stars; and</p> <p>(b) for <i>JV1(a)(ii)</i> the average <i>software rating</i> of all <i>sole occupancy units</i> is not less than 5 star; and</p> <p>(c) the deemed to satisfy provisions of Section J of the <i>BCA 2009</i> (Volume 1) have no effect for <i>sole occupancy units</i>.</p> <p>(2) For the purposes of calculating the average <i>software rating</i> under <i>A2(1)(b)</i> of all <i>sole occupancy units</i> of a <i>class 2</i> building in <i>climate zones 1</i> or <i>2</i> the following credits apply towards the <i>software rating</i> for each <i>sole occupancy unit</i>:</p> <p>(a) 0.5 star where a <i>sole occupancy unit</i> includes an <i>outdoor living area</i>, the roof covering of which achieves a <i>Total R-Value</i> of 1.5 for downward heat flow; or</p> <p>(b) 1 star where a <i>sole occupancy unit</i> includes an <i>outdoor living area</i> that has at least one permanently fixed ceiling fan with a speed controller and a blade rotation diameter of not less than 900mm and the roof covering achieves a <i>Total R-Value</i> of 1.5 for downward heat</p> |
|-----------|--|-----------|---|

outdoor living area includes a permanently installed ceiling fan with a speed controller and a blade rotation diameter of not less than 900 mm;

- (c) 1 star where a building has a solar photovoltaic system of at least 1kW in capacity (maximum power output) is installed.

PERFORMANCE REQUIREMENTS**ACCEPTABLE SOLUTIONS**

flow.

- (3) To achieve a credit under **A2** (2)(b) an *air-conditioner* that services any room directly adjacent to an *outdoor living area* must automatically shut down when an external door that provides access to the *outdoor living area* is open for more than 1 minute.

Energy Efficient Domestic Services

P3	For <i>class 1</i> buildings and an enclosed <i>class 10a</i> building attached to a <i>class 1</i> building, artificial lighting complies with <i>performance requirement P2.6.2(a)</i> of <i>BCA 2010</i> (Volume 2)	A3	<i>Class 1</i> buildings, including a verandah, balcony or an enclosed <i>class 10a</i> building attached to a <i>class 1</i> building, have: <ul style="list-style-type: none"> (a) artificial lighting that complies with Part 3.12.5.5 of <i>BCA 2010</i> (Volume 2); or (b) <i>energy efficient lighting</i> for a minimum of 80 per cent of total fixed artificial lighting.
P4	In <i>sole occupancy units</i> of <i>class 2</i> buildings fixed artificial lighting must be energy efficient.	A4	<i>Sole occupancy units</i> of <i>class 2</i> buildings, including a verandah, balcony or an enclosed <i>class 10a</i> building attached to a <i>class 2</i> building, have <i>energy efficient lighting</i> for a minimum of 80 per cent of total fixed artificial lighting.
P5	For <i>class 1</i> buildings hot water systems comply with the Queensland Plumbing and Wastewater Code.	A5	For hot water systems for a <i>class 1</i> building: <ul style="list-style-type: none"> (c) disregard <i>BCA 2010</i> (Volume 2) 3.12.5.6; and instead (d) comply with the Queensland Plumbing and Wastewater Code.
P6	Repealed ²	A6	Repealed ²

² The performance requirement and acceptable solution regarding the installation of air-conditioners was repealed on 1 August 2012.

Water Conservation

- P7** In *class 1* and *class 2* buildings, in areas serviced by a *water service provider*, shower roses must facilitate the efficient use of water.
- A7** In *class 1* and *class 2* buildings, in areas serviced by a *water service provider*, all shower roses have a minimum 3-star Water Efficiency Labelling and Standards rating.
- Note:** Water Efficiency Labelling and Standards (WELS) – references the Australian Government’s labelling and standards scheme for water efficient products.
- P8** In *class 1* and *class 2* buildings, in areas serviced by a *water service provider*, toilet cisterns and bowls must facilitate the efficient use of water.
- A8** In *class 1* and *class 2* buildings, in areas serviced by a *water service provider*, all toilet cisterns:
- (a) have a dual flush function and have a minimum 4-star Water Efficiency Labelling and Standards rating; and
 - (b) are compatible with the size of the toilet bowl to allow for proper functioning of the toilet.
- P9** In *class 1* and *class 2* buildings, in areas serviced by a *water service provider*, tap ware must facilitate the efficient use of water.
- A9** In *class 1* and *class 2* buildings, in areas serviced by a *water service provider*, tap ware with a minimum 3-star Water Efficiency Labelling and Standards rating serves:
- (a) laundry tubs; and
 - (b) kitchen sinks; and
 - (c) basins.

Electricity Sub-metering

- P10** The *electricity* supplied to each *meterable premises* is able to be measured.
- A10** Each *meterable premises* has an *electricity sub-meter* installed which measures only the *electricity* supplied to that *meterable premises*.
- P11** An *electricity meter* must be located so it is easy and safe to read and maintain at any reasonable time.
- A11** The *electricity sub-meter* is:
- (a) installed in a *common area*; and
 - (b) free of hindrance or obstruction to a person authorised to read and/or maintain the *electricity sub-meter*.
- P12** The *electricity meter* for each *meterable premises* must be labelled to indicate which *meterable premises* it is associated with.
- A12** A *meter label* identifying which *meterable premises* it is associated with is affixed or located adjacent to the *electricity sub-meter* for each *meterable premises*.

End of Trip Facilities

- P13** (1) *End of trip facilities* are provided for *employees* or *occupants*, in the building or on-site within a reasonable walking distance, and include:
- (a) adequate *bicycle parking and storage facilities*; and
 - (b) adequate provision for securing belongings; and
 - (c) *change rooms* that include adequate *showers, sanitary compartments, wash basins* and mirrors.
- (2) Notwithstanding (1) there is no requirement to provide *end of trip facilities* if it would be unreasonable to provide these facilities having regard to:
- (a) the projected population growth and forward planning for road upgrading and development of cycle paths; or
 - (b) whether it would be practical to commute to and from the building on a *bicycle*, having regard to the likely commute distances and nature of the terrain; or
 - (c) the condition of the road and the nature and amount of traffic potentially affecting the safety of commuters.
- A13** (1) *Bicycle parking and storage facilities* are:
- (a) easily accessible and provided in the building, or on-site within 100 metres of an *entrance* to the building, in accordance with:
 - (i) five percent (5%) of the number of *employees*, based on *workforce numbers*; or
 - (ii) the *occupant* ratios in Schedule 3 (rounded up to the nearest whole number); and
 - (b) designed and constructed in compliance with AS 2890.3:1993 (including modifications as specified in Schedule 2).
- (2) *Lockers* are:
- (a) provided in the building, or on-site within 100 metres of an *entrance* to the building, on a 1.6:1 ratio for every *bicycle* parking space; and
 - (b) co-located or located within 50 metres of *change rooms* required by A13(3) of this part; and
 - (c) provided with minimum dimensions of 900mm (height) x 300mm (width) x 450mm (depth).
- (3) *Change rooms*:
- (a) are provided in the building, or on-site within 100 metres of an *entrance* to the building and comply with Schedule 4, Table A, Column B; and
 - i) are fitted with a lockable door or otherwise screened from public view; and
 - ii) are located within 100 metres of *bicycle parking and storage facilities* required by A13(1) of this part if the *bicycle parking and storage facilities* and *change rooms* are not located in the building.
- (4) *Change rooms* provide:

P13
cont-
inued

- (a) *showers* that:
 - (i) are located within *change rooms* and meet Schedule 4, Table A, Column C; and
 - (ii) have a minimum 3-star Water Efficiency Labelling and Standards (WELS) rating *shower head*; and
 - (iii) dispense both hot and cold water; and
 - (b) *sanitary compartments* that:
 - (i) are located within *change rooms*, and meet Schedule 4, Table A, Column D; and
 - (ii) are constructed in compliance with F2.3 (e) and F2.5 of *BCA* (Volume 1); and
 - (c) wash basins that are located within *change rooms* and meet Schedule 4, Table A, Column E; and
 - (d) a mirror located above wash basins; and
 - (e) a hook and bench seating located within each *shower compartment*; and
 - (f) a socket-outlet located adjacent to each wash basin.
- (5) Where *change room* requirements are predominantly located in a carpark or on a basement floor that is not regularly used by *occupants* or *employees*, they may not be counted towards the requirements of the *BCA*, Volume 1 Part F2.
- (6) Notwithstanding ((1), (2), (3) & (4)), a local government planning scheme may require additional *bicycle parking and storage facilities, locker facilities, change rooms, showers, sanitary compartments, wash basins and mirrors.*

Note 1: For A13(1) (a) – the *occupant* ratios may be used where *employees* based on *workforce numbers* cannot be determined accurately.

Note 2: For A13(6) – refer to the Department's website for a list of local governments that have existing *end of trip facility* requirements in their planning schemes. It is recommended that in all cases confirmation be obtained from the relevant local government as to whether it has any relevant *end of trip facility* requirements in its planning scheme.

Schedule 1

<i>Designated Local Government</i>
Brisbane City Council
Bundaberg Regional Council
Cairns Regional Council
Central Highlands Regional Council
Fraser Coast Regional Council
Gladstone Regional Council
Gold Coast Regional Council
Gympie Regional Council
Ipswich City Council
Logan City Council
Mackay Regional Council
Moreton Bay Regional Council
Mount Isa City Council
Redland City Council
Rockhampton Regional Council
Southern Downs Regional Council
Sunshine Coast Regional Council
Toowoomba Regional Council
Townsville City Council
Western Downs Regional Council

Schedule 2

Standard clauses affected	Standard modifications
AS 2890.3:1993	
2.2.4	In addition to 2.2.4: Vertical storage can also comprise alternative <i>bicycle</i> storage area requirements that are available within the marketplace (e.g. wall mounted rails and racks, pods).
2.2.6	In addition to 2.2.6: Open plan storage layouts can also comprise alternative <i>bicycle</i> storage area requirements that are available within the marketplace (e.g. double parker/double storey parking systems, pods).
Figure 2.1	Figure 1 also applies in addition to Figure 2.1.

Figure 1

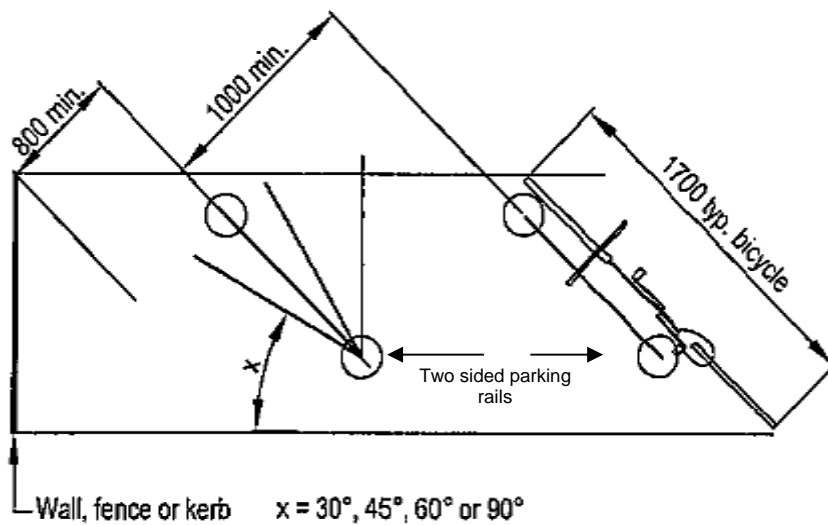

Schedule 3

(A) Building Type	(B) Bicycle Spaces	(C) Security Classification (refer AS 2890.3, Table 3.1)
<i>Commercial office building</i>	1 per 30 occupants	2
<i>Shopping centre</i>	1 per 500 occupants	2
<i>Tertiary education facility</i>	1 per 375 occupants	2
<i>Hospital</i>	1 per 100 occupants	2

Schedule 4

Table A

(A) Change room requirements based on <i>bicycle</i> parking spaces	User Group	(B) Change room provisions	(C) Number of <i>showers</i> required	(D) Number of <i>sanitary compartments</i> required	(E) Number of wash basins required
1 – 5	Female and Male	1 <i>change room</i> of <i>unisex design</i>	1	1 closet pan	1
6-19	Female	1	1	1 closet pan	1
	Male	1	1	1 closet pan	1
20 or more	Female	1	2, plus 1 additional <i>shower</i> for every 20 <i>bicycle</i> parking spaces provided thereafter*.	2 closet pans, plus 1 additional <i>sanitary compartment</i> for every 60 <i>bicycle</i> parking spaces provided thereafter*.	1, plus 1 additional wash basin for every 60 <i>bicycle</i> parking spaces provided thereafter*.
	Male	1	2, plus 1 additional <i>shower</i> for every 20 <i>bicycle</i> parking spaces provided thereafter*.	1 urinal and 1 closet pan, plus 1 additional <i>sanitary compartment</i> at the rate of 1 closet pan or 1 urinal for every 60 <i>bicycle</i> parking spaces provided thereafter*.	1, plus 1 additional wash basin for every 60 <i>bicycle</i> parking spaces provided thereafter*.

*Refer **Table B** for example of workings.

Table B

	User Group	20-39 <i>bicycle</i> parking spaces	40-59 <i>bicycle</i> parking spaces	60-79 <i>bicycle</i> parking spaces	80-99 <i>bicycle</i> parking spaces	100-119 <i>bicycle</i> parking spaces
Number of <i>showers</i> required	Female	2	3	4	5	6
	Male	2	3	4	5	6
Number of <i>sanitary compartments</i> required	Female	2	2	2	3	3
	Male	2	2	2	3	3
Number of wash basins required	Female	1	1	1	2	2
	Male	1	1	1	2	2