



CHIEF EXECUTIVE APPROVAL 02/2018
Plumbing and Drainage Act 2002, part 5.

Approval

1. The **Econocycle ENC10-1** ("the system") described in the Specifications and Drawings in the attached Schedule and manufactured by **Eco-Septic Pty Ltd** ("the manufacturer") (ABN 086 310 474) has been assessed in accordance with the Queensland Plumbing and Wastewater Code (QPW Code) dated 15 January 2013.
2. Approval is granted for the secondary quality wastewater treatment system, subject to compliance by the manufacturer with the requirements of the *Plumbing and Drainage Act 2002*, part 5 and the conditions of approval detailed below.
3. This approval, the conditions of approval and the Schedule comprise the entire Chief Executive Approval document.
4. Any modification by the manufacturer to the design, drawings or specifications scheduled to this approval must be approved by the Chief Executive.

Conditions of approval

5. The manufacture, installation, operation, service and maintenance of the systems must be in conformity with the conditions of this Chief Executive Approval.
6. The secondary quality wastewater treatment system may only be used on premises that generate per day:
 - (a) a maximum hydraulic loading of 2000L; and
 - (b) a maximum organic loading of 700g BOD₅
7. For the system to meet the requirements of a secondary quality wastewater treatment system, the system must produce the following effluent quality —
 - (a) 90% of the samples taken must have a BOD₅ less than or equal 20g/m³ with no sample greater than 30g/m³; and
 - (b) 90% of the samples taken must have total suspended solids less than or equal 30g/m³ with no sample greater than 45g/m³; and
 - (c) 90% of the samples taken must have thermotolerant coliform count not exceeding 200 organisms per 100 mL with no sample exceeding 1000 organisms per 100mL.
8. Each system must be serviced in accordance with the manufacturers details supplied in the owner's service and maintenance manuals.
9. Each system must be supplied with —
 - (a) a copy of this Chief Executive Approval document;
 - (b) details of the system and ancillary equipment;
 - (c) instructions for authorised persons for its installation;
 - (d) a copy of the owner's manual to be given to the owner at the time of installation; and
 - (e) detailed instructions for authorised service personal for its operation and maintenance.

10. This approval does not extend, apply to, or include the land application system used in conjunction with an approved system installed on premises.
11. At each anniversary of the Chief Executive Approval date, the manufacturer must submit to the Chief Executive a list of all systems installed in Queensland that they have received an installation and commissioning certificate for during the previous 12 months.
12. Where the Chief Executive is notified of any system failures that are believed to be the result of poor design or faulty manufacture, the Chief Executive may randomly select a number of installed systems for audit. The Chief Executive will notify the National Association of Testing Agencies (NATA) accredited laboratory nominated by the manufacturer, which systems are to be audited for Biochemical Oxygen Demand (BOD₅) and Total Suspended Solids (TSS). The sampling and testing of the selected systems, if required, is to be done at the manufacturer's expense. The following results must be reported to the Chief Executive;
 - (a) Address of premises.
 - (b) Date inspected and sampled.
 - (c) Sample identification number.
 - (d) Biochemical Oxygen Demand (BOD₅).
 - (e) Total Suspended Solids (TSS).
13. The Chief Executive may, by written notice, cancel this approval if the manufacturer fails — to comply with one or more of the conditions of approval; or within 30 days, to remedy a breach, for which a written notice been given by the Chief Executive.
14. This approval may only be assigned with the prior written consent of the Chief Executive.
15. This approval expires on 12 August 2023 unless cancelled earlier in accordance with paragraph 13 above.



Lindsay Walker
Director
Building Legislation & Policy

Date approved: 13 August 2018

Level 16,
41 George Street Brisbane
GPO Box 2457, Brisbane Qld 4001
Telephone +61 7 300 82552
Facsimile +61 7 323 71248
Website www.hpw.qld.gov.au

ABN 61 331 950 314

CHIEF EXECUTIVE APPROVAL No. 02/2018
Plumbing and Drainage Act 2002, part 5, division 1, section 93

SCHEDULE

Attachment 1

Specifications for the

Econocycle ENC10-1

Department of Housing and Public Works	
Chief Executive Approval	
Approval No:	02/2018
Date of Issue:	13/12/18
Delegate Signature:	
Building Codes Queensland	

MODEL ENC10-1 SPECIFICATION

- | | |
|-------------------------------------|--|
| 1) Number of persons | 10 |
| 2) Temperature & Humidity range | -2°C - 45°C
12% - 95% |
| 3) Tanks | Single 7000 litre min concrete tank |
| 4) Blower | 80 litres per minute - Nitto LA80 / Hi Blow 80 |
| 5) Irrigation Pump | 7.5 metre head automatic start |
| 6) Septic Section | 3050 litres. Tank with baffle at 2/3 -1/3 position |
| 7) Aeration Section | 2500 litres min of aeration divided into two sections |
| 8) Clarifier | 0.45m ² / 0.45m ² per person / 420 litres |
| 9) Chlorine contact & Pump-Out Tank | 420 litres. Tank with internal pump out section |
| 10) Media | 50m ² (2 packs x 500 x 800 x 800mm)
Aqua Cool CF1900 |
| 11) Diffusers | 2 x 800mm |
| 12) Chlorinator | 1 Chlorine Canister (space for 2 nd if required) |

Department of Housing and Public Works	
Chief Executive Approval	
Approval No:	02/2018
Date of Issue:	13/8/18
Delegate Signature:	
Building Codes Queensland	

CHIEF EXECUTIVE APPROVAL No. 02/2018
Plumbing and Drainage Act 2002, part 5, division 1, section 93

SCHEDULE

Attachment 2

Drawings for the

Econocycle ENC10-1

Department of Housing and Public Works	
Chief Executive Approval	
Approval No:	<u>02/2018</u>
Date of Issue:	<u>13/8/18</u>
Delegate Signature:	<u></u>
Building Codes Queensland	

1

2

3

4

5

6

A

B

C

D

A

B

C

D

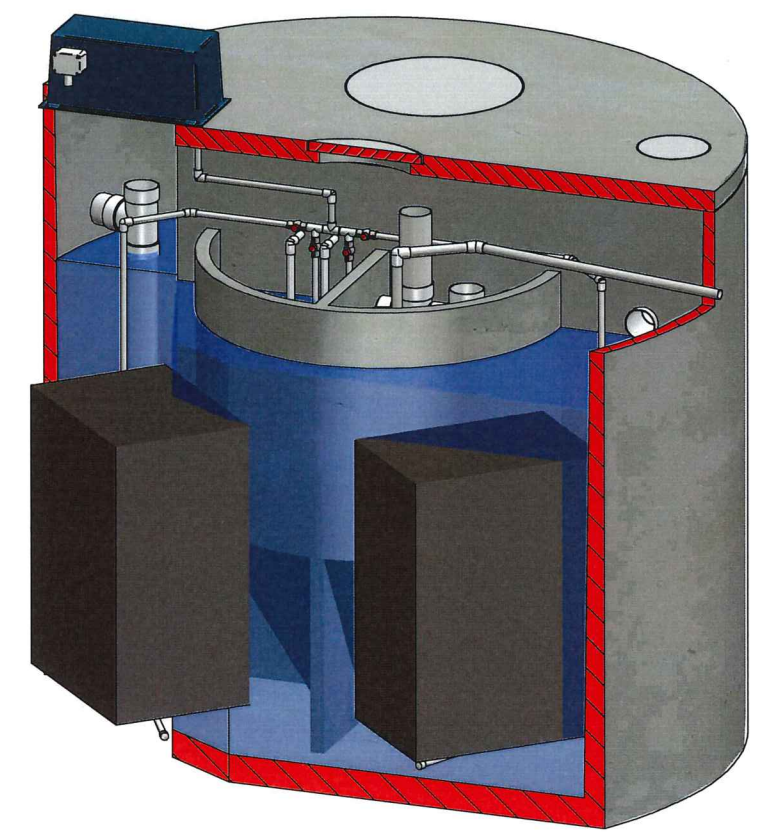
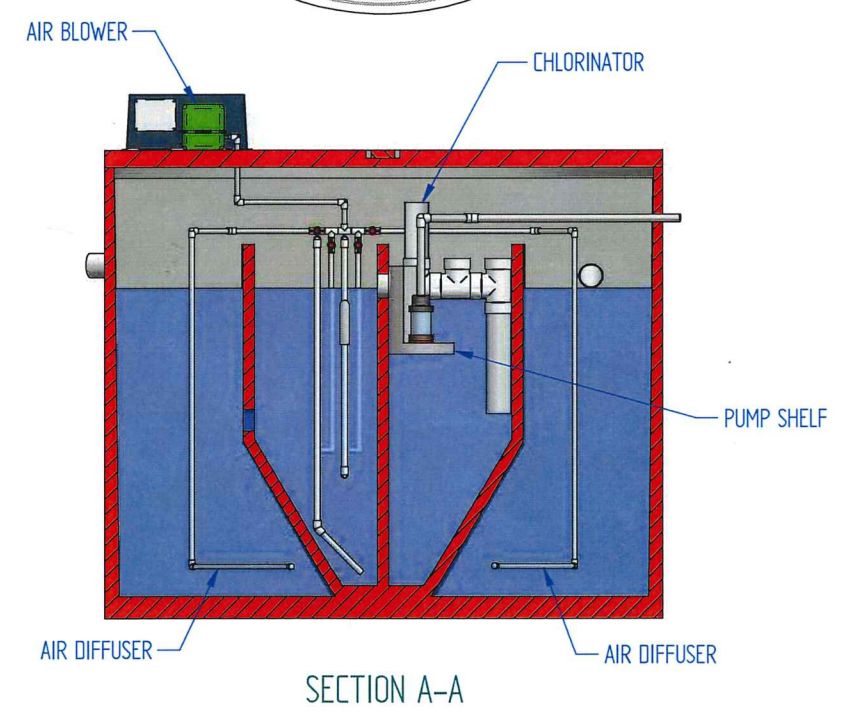
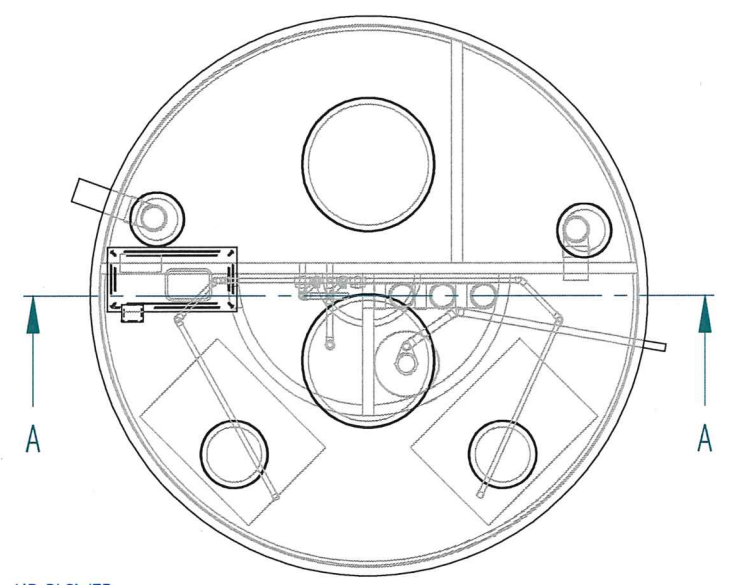
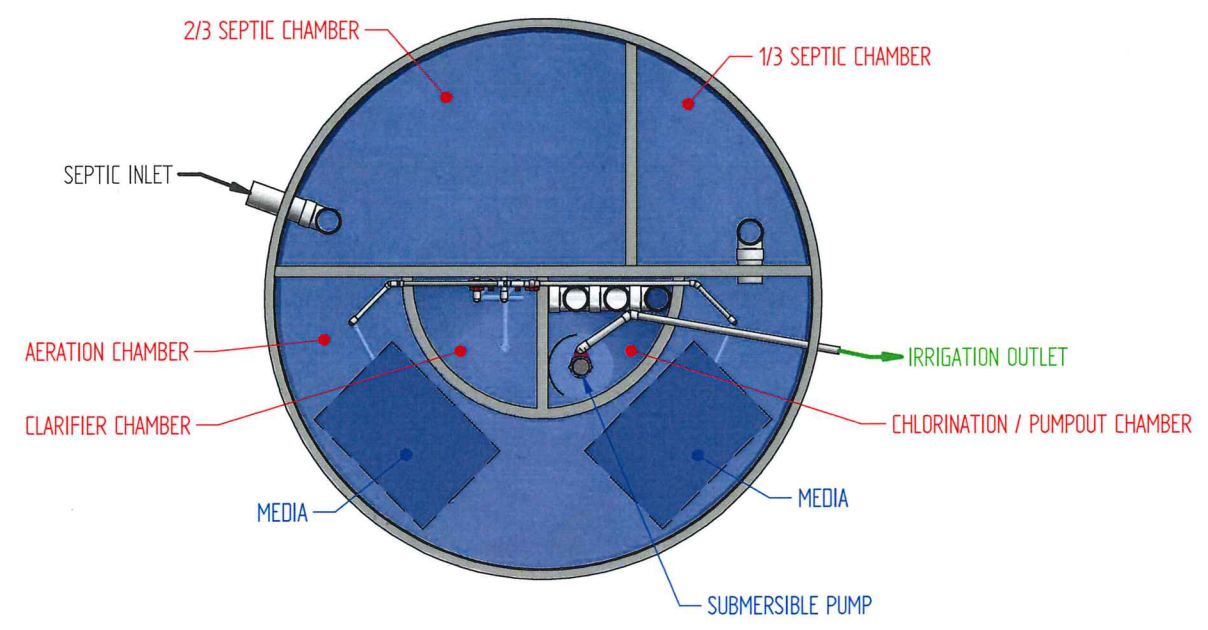

Department of Housing and Public Works
Chief Executive Approval
 Approval No: 02/2018
 Date of Issue: 13/2/18
 Delegate Signature: [Signature]
 Building Codes Queensland

NOTES:
 1. SYSTEM CAPACITY: 10 PEOPLE
 2. SEPTIC TANKS MANUFACTURED AND TESTED IN ACCORDANCE WITH AS/NZS 1546.1:2008

<p>Econocycle <small>AERATED WASTEWATER TREATMENT SYSTEMS</small></p>	<p>UNLESS OTHERWISE SPECIFIED ALL DIMENSIONS ARE IN MM</p>	PROJECT	ENC10-1	
		TITLE	TANK ASSY CERTIFICATION DRAWING	
<p>COPYRIGHT <small>THIS DRAWING AND INFORMATION CONTAINED HEREIN REMAINS THE COPYRIGHT PROPERTY OF ECONOCYCLE AND CANNOT BE COPIED OR REPRODUCED WITHOUT WRITTEN PERMISSION</small></p>	SCALE	DATE PLOTTED	COAT/TREAT.	SHEET SIZE
	DO NOT SCALE	24/09/2010	-	A3
	DRAWN BY	DRAWING LAST MODIFIED BY	PART#	REVISION
	P. MCKAY	P. MCKAY	124_0710	2.G
	MODELLED BY	MODEL LAST MODIFIED BY		SHEET No.
	P. MCKAY	P. MCKAY		1 OF 1

1

2

3

4

5

6